

Spyder3 CL SC-34

Bilinear Color CameraLink Linescan Camera



Key Features

- 2k and 4k resolutions
- Extended temperature range
- RGB, RG/BG, or G output formats
- Pre-calibrated light sources
- Cost-effective
- Ease of use
- Camera Link configuration

Programmability

- Automatic white balance
- Color correction
- Bidirectional
- Flat field correction

Typical Applications

- Wood and tile inspection
- Cotton and textile
- Food, drug, and tobacco inspection
- Recycling sorting
- General machine vision

Overview

Low-cost, ease of use, flexibility.

Teledyne DALSA's Spyder3 Color CL camera is a color line scan camera based on the successful Spyder3 dual line scan monochrome model. This camera provides a low cost solution with high color fidelity, flexibility, and ease of use and setup.

The Spyder3 Color CL has the red and blue color pixels alternating in one line and all the green pixels in the other line with no spacing between the two lines to minimize image artifacts. The camera offers several color output format options, including RGB, RG/BG, or G only to meet different imaging requirements.

The temperature range performance of the SC-34 models has increased from an operating temperature of 0 °C to 50 °C to an operating temperature of 0 °C to 65 °C.

The Spyder3 Color CL camera also incorporates advanced features such as flat field correction, automatic white balance, and the camera's are pre-calibrated to light sources such as white LEDs for improved ease of use.

Specifications

Resolution	2048 x 2 pixels / 4096 x 2 pixels
Data Rate	80 megapixels per second
Max. Line/Frame Rate	18 kHz (2k) / 9 kHz (4k)
Pixel Size	14 μm x 14 μm (2k) / 10 μm x 10 μm (4k)
Data Format	8 bit, 12 bit selectable
Output	Camera Link
Lens Mount	M42, C, F (2k) M58, F (4k)
Responsivity	8 DN (nJ/cm ²) @ 0dB, 8 bit (2k) 4 DN (nJ/cm ²) @ 0dB, 8 bit (4k)
Dynamic Range	60 dB
Nominal Gain Range	0~20 dB
Size	72 mm x 60 mm x 60 mm, 2k camera 60 mm x 72 mm x 60 mm, 4k camera
Mass	300 g
Operating Temp	0 °C to 65 °C
Power Supply	+12 V to +15 V
Power Dissipation	< 9 W
Regulatory Compliance	CE and RoHS
Control	MDR26 female Camera Link
Data	Shared with control
Power	Hirose 6 HR10 pin male
Example Part Number	SC-34-04k80-00-R

Spyder3 CL SC-34

Bilinear Color CameraLink Linescan Camera

The Spyder3 Color CL camera is a cost-effective and easy-to-use bilinear color linescan camera.

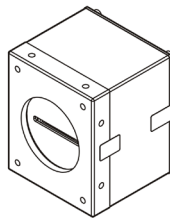
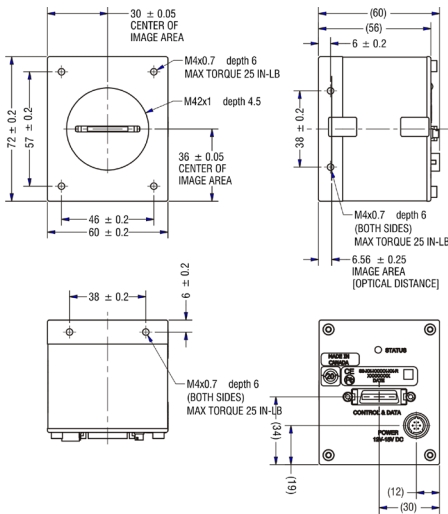

2k models

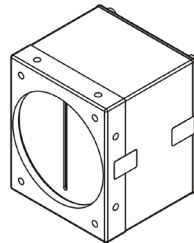
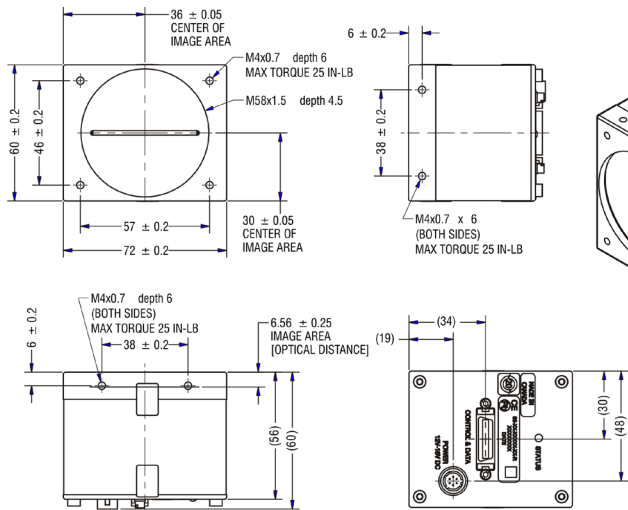
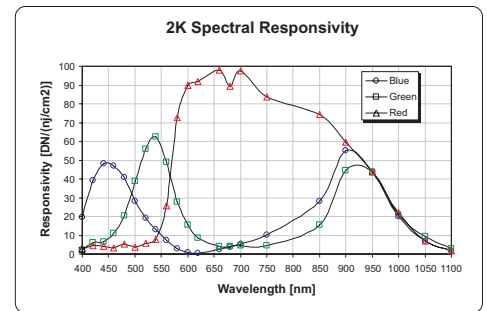

4k model

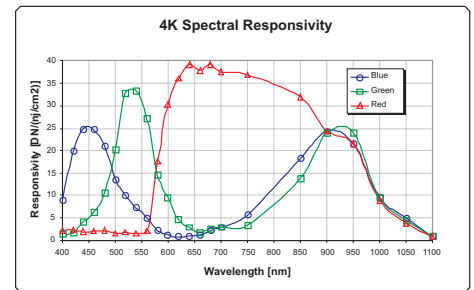

www.teledynedalsa.com

Americas

Boston, USA
+1 978-670-2000
sales.americas@teledynedalsa.com

Europe

Munich, Germany
+49 8142-46770
sales.europe@teledynedalsa.com

Asia Pacific

Tokyo, Japan
+81 3-5960-6353
sales.asia@teledynedalsa.com

Shanghai, China
+86 21-3368-0027
sales.asia@teledynedalsa.com